

CAD FILE:

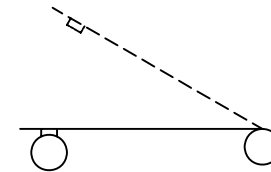
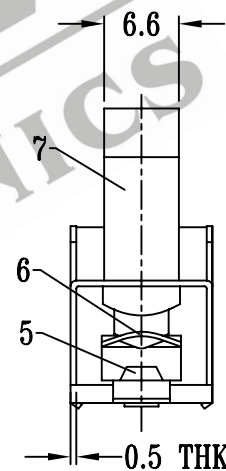
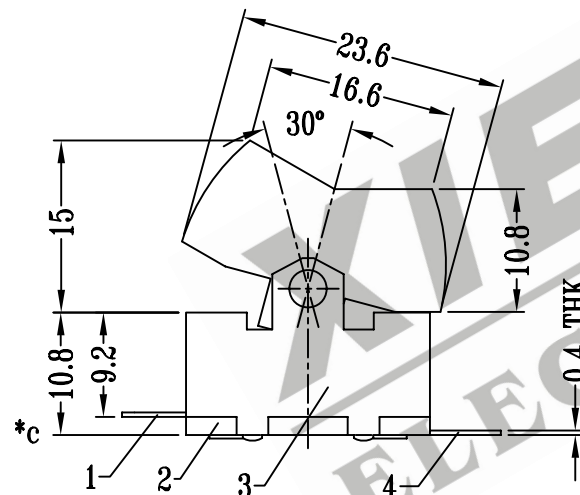
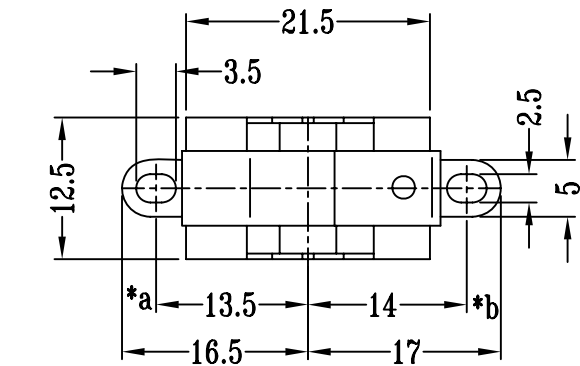

SCHMATIC

注:带"*"表示关键尺寸(3个)

9	STEEL BALL	STEEL	1	NATURAL	TOLERANCE UNLESS SPECIFIED	SHENZHEN XIEJIA ELECTRONICS CO.,LTD.				
8	SPRING	STEEL WIRE	1	TEMPER						
7	KNOB	PC	1	BLACK	WITHIN: 1.5±0.1mm OVER : 1.5±0.2mm	ISSUE	DATE	DESCRIPTIONS		APPD.
6	CONTACT B	BRASS STRIP	1	Ag PLATED						
5	CONTACT A	COPPER	2	Ag PLATED	TITLE : ROCKER SWITCH					
4	TERMINAL B	BRASS STRIP	1	Ag PLATED OVER Ni PLATED						
3	FRAME	STEEL STRIP	1	Zn PLATED	MODEL: RS-1122					
2	TERMINAL BASE	PHENOLIC RESIN	1	BLACK						
1	TERMINAL A	BRASS STRIP	1	Ag PLATED OVER Ni PLATED	ALL MATERIALS MUST BE COMPLIANT TO ROHS					
NO.	PART NAME	MATERIAL	Q'TY	FINISHING						